

Appendix A

The KTD-404 contains a DIP switch which, under special circumstances, the installer may have to access.

Locating the DIP Switch

The figure below shows the location of the DIP switch on the KTD-404 and KTD-304R.

CAUTION:



Do not change any DIP switch settings unless directed to do so by Kalatel technical support. All DIP switch positions should be OFF.

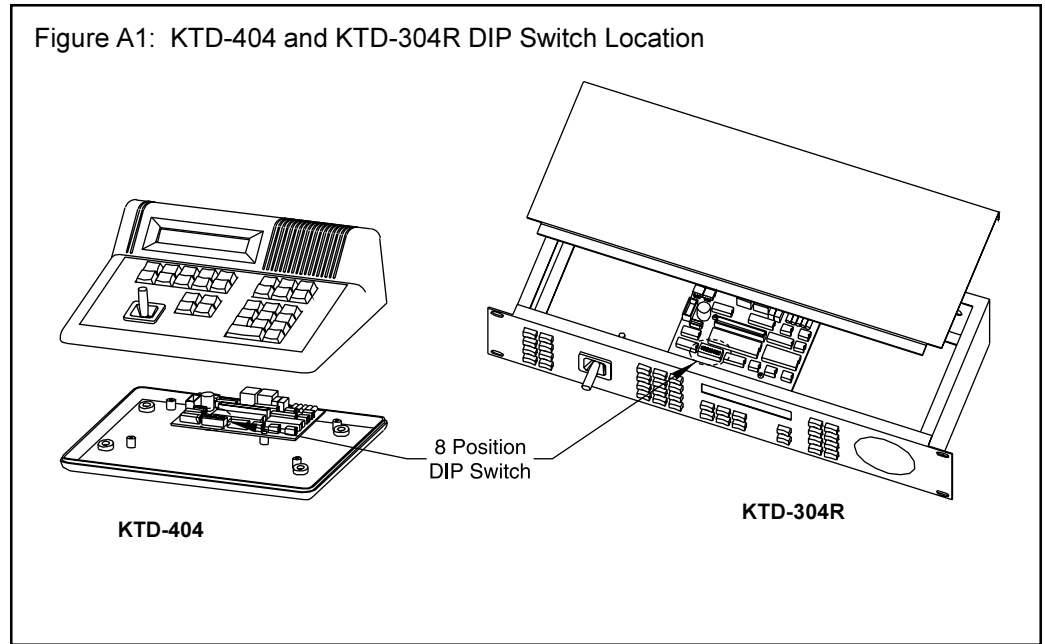

Appendix B Keypad Replacement

The **talk** and **face** keycaps on the KTD-404 series keypads can be easily removed and replaced with the **enter** keycap if Entry Verification is enabled (See *KTD-404 Programming*). An **enter** keycap has been provided. The following steps illustrate keycap removal and replacement.

KTD-404: Refer to Figure B1, below.

Step 1) Use a small flat-head screwdriver to gently pry off the **talk** keycap.

Step 2) Align the **enter** keycap over the cruciform stem, and press firmly until it snaps into place.

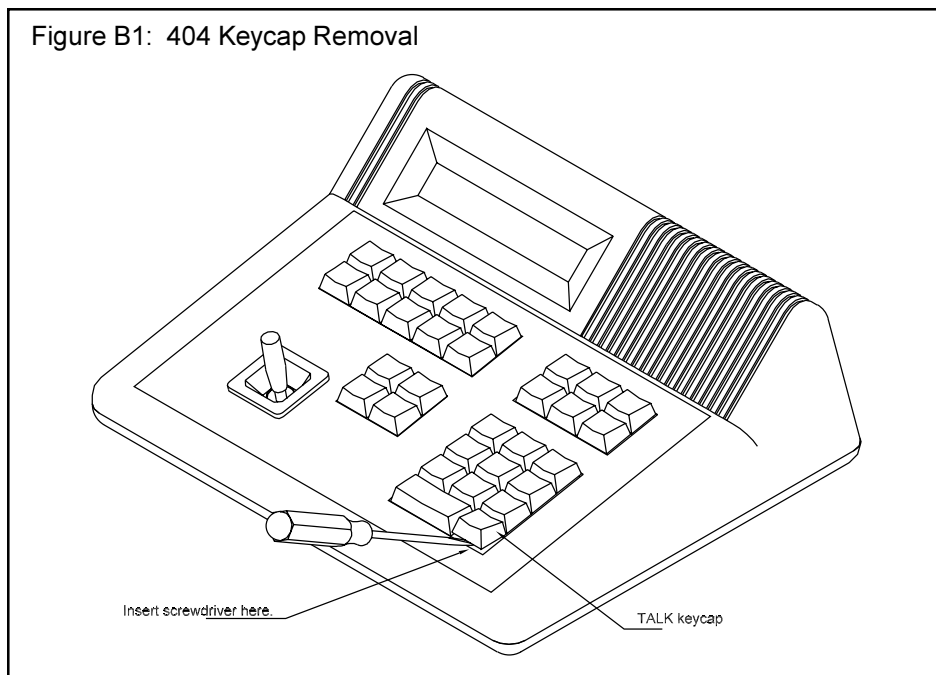

KTD-304R: Refer to Figure B2, below.

Step 1) Grasp the **face** keycap with a pair of pliers and pull gently to remove it.

Step 2) Align the **enter** keycap over the cruciform stem, and press firmly until it snaps into place.

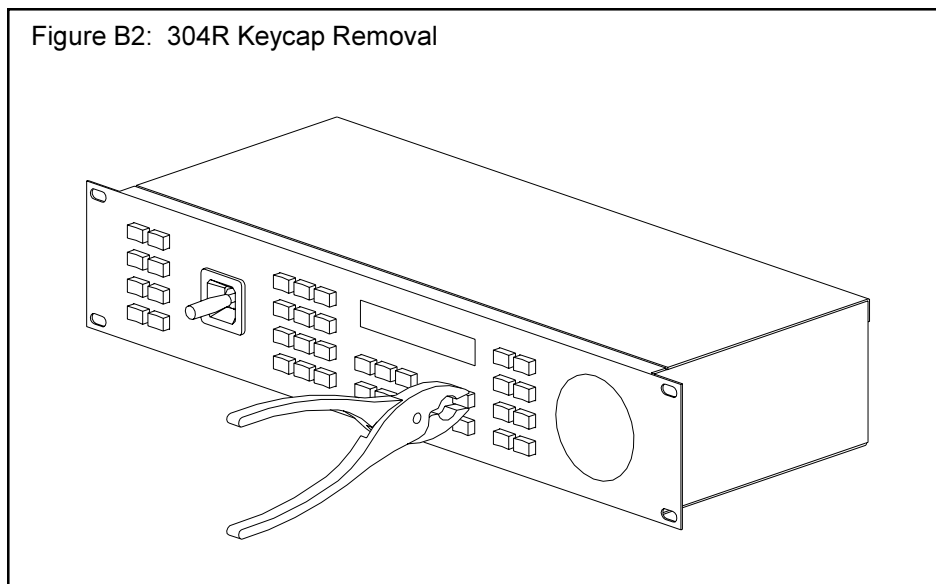

Appendix C

Current Parameters Display

There may be an occasion when the user needs to know to current parameters set on KTD-404 (for example, during a technical support call).

To view the current parameters, press and hold the **mon** key until the following display appears on the LCD window:

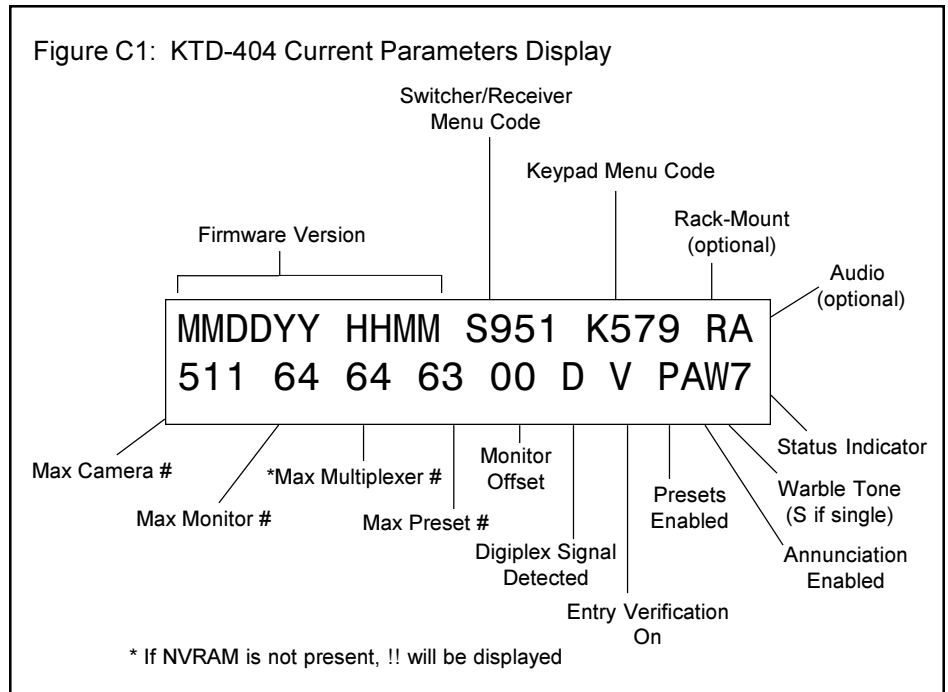

To exit this display, press any number key or move the joystick.

Appendix D

Warranty & Return Information

Three-Year Warranty

Kalatel, Inc. warrants its products for a period of three (3) years from the date of factory shipment. The warranty specifically covers any defects in material and workmanship, and does not cover equipment that has been abused, damaged or modified.

NOTE: This warranty does not apply to the InView™, MobileView™, DIGIPLEX Remote™ or Paragon™ systems. These systems carry a 14-month warranty from date of invoice.

Return Guidelines

For all returns, please be prepared to provide tech support with the following information:

- Company name, address, telephone number and fax number.
- Where the product was purchased.
- Purchase order or invoice number the product was purchased on.
- Model and serial number.
- Details of the defect.

An RMA number will be issued for all returns. Please write the RMA number on the outside of the package(s).

Contact Technical Support for an RMA Number

Telephone: (800) 469-1676, between 6:00AM and 5:00PM Pacific Time, Monday through Friday

Fax (Tech Support): (541) 752-9096, available 24 hours a day

Mail: PO Box 3004-225, Corvallis, OR 97339

Ship (with RMA): 728 SW Wake Robin Ave, Corvallis, OR 97333 USA

Kalatel offers 24-hour technical support assistance seven days a week. Please call 1-800-469-1676 during normal business hours: 6 a.m. to 5 p.m. (PST). If calling after hours (between 5 p.m. and 6 a.m. PST) or on weekends, please call 541-740-3589.

Advance Replacement

A Purchase Order number must be issued for any Advance Replacement. We will evaluate the condition of the returned equipment and deduct any restocking or refurbishing fees, if any, from the credit transaction.

Loaner/Repairs

A Purchase Order number must be issued for any equipment loan or repair transaction. Non-warranty repairs are subjected to a minimum charge of \$15.00. When requesting an RMA number, it is recommended that the request be made directly by the technician involved in the servicing or installation of the equipment. If this is not possible, a detailed description of the problem is necessary.

