

SONY®

NTSC

Color Video Cameras

SSC-DC193/DC393



Lens is optional.

Color Video Cameras

SSC-DC193/DC393



Sony's new versatile and stylish SSC-DC193 and SSC-DC393 color cameras are specifically designed for surveillance and monitoring applications ranging from building and airport security to banking and retail stores, and more!

Incorporating the latest Sony CCD technology, these cameras produce images with high picture quality and remarkable sensitivity with a S/N ratio of more than 50 dB. In addition, these cameras incorporate Sony's DSP (Digital Signal Processing) technology providing a high level of stability and reliability that cannot be achieved with an analog signal processor. The SSC-DC193 and SSC-DC393 offer dual power capability (AC 24 V and DC 12 V) to safeguard against unwanted power supply compatibility issues.

The SSC-DC193 and SSC-DC393 cameras are encased in an aesthetically pleasing and compact design perfectly suited for commercial and fashionable facilities such as retail stores, shopping malls, stadiums, arenas, banks and office buildings. What's more, these cameras are equipped with outstanding features including Back-Light Compensation to counteract shadow casting, Auto-Tracking White Balance, CCD IRIS™, Turbo AGC (up to 24 dB) enabling subjects within low illuminated areas to be more clearly distinguished, and an extensive choice of lens options and connection capability.

Sony's SSC-DC193 and SSC-DC393 cameras are the ideal choice for a wide range of surveillance applications - offering excellent performance, dependability and sophisticated design, all at an affordable price.

High picture quality

The SSC-DC393 camera incorporates a 1/3 type IT (Interline Transfer) CCD with Exwave HAD™ technology, the new Sony technology that offers extremely high picture quality and high sensitivity. The high resolution SSC-DC393 camera provides 480 TV lines and a minimum illumination of 0.7 lx at F1.2 (50 IRE).

The SSC-DC193 camera incorporates a 1/3 type IT Super HAD CCD™ that achieves a horizontal resolution of 330 TV lines and a minimum illumination of 0.6 lx at F1.2 (50 IRE).

Compact and stylish design

With dimensions of 60 (W) x 54 (H) x 120 (D) mm and weighing only 360 g, these compact cameras can easily be installed in places where space is limited and installation was previously difficult for larger cameras. Their stylish and unobtrusive, metallic-silver design will complement any décor.

Tripod screw holes

Installing and setting up your camera is simple, because it already includes tripod screw holes at the top and bottom of its body. You do not need a special tripod adaptor.

DSP technology

These new cameras incorporate Sony's Digital Signal Processing (DSP) technology for powerful picture contrast controls. Providing outstanding stability over long periods of time and reliability levels unattainable with analog signal processors, the SSC-DC193 and SSC-DC393 color cameras capture superb images under various lighting conditions.



Typical System

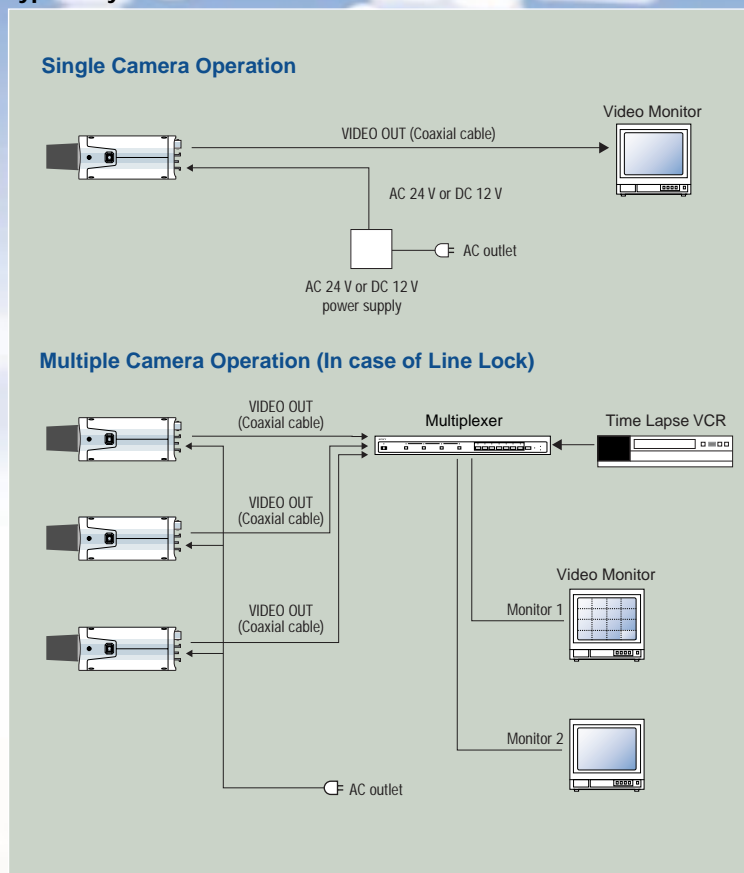

Back-Light Compensation (BLC)

Unwanted backlighting can often cause the subject matter of the image to be cast into shadows. The Back-Light Compensation (BLC) feature incorporated in these cameras will automatically compensate for such conditions and allow the subject to be easily visible with an improved level of object recognition.

DC servo/video servo lens connection capability

The SSC-DC193 and SSC-DC393 cameras can connect easily with either DC servo or video servo lenses.

AC 24 V/DC 12 V operation

These cameras accept either AC 24 V or DC 12 V power sources and will automatically switch to the appropriate mode upon receiving power.

CCD IRIS

This function allows the use of a manual iris lens instead of a more costly automatic iris lens. As the scene illumination level increases, these camera respond by automatically reducing the exposure time of the photosensors.

This is achieved by changing the electronic shutter speed of the CCD, in the range of 1/60 to 1/100,000 of a second.

CS-mount

These cameras can be used with CS-mount lenses, allowing for easy and precise back-focus adjustments.



Specifications

	SSC-DC193	SSC-DC393
Image device	1/3 type Interline Transfer CCD	
Picture elements (H x V)	510 x 492	768 x 494
Sensing area	1/3" format (4.8 x 3.6 mm)	
Signal system	NTSC standard	
Sync. System	INT/LL	
Horizontal resolution	330 TV lines	480 TV lines
Lens mount	CS	
Minimum illumination	0.3 lx at F1.2 (30 IRE, AGC ON, Turbo mode) 0.6 lx at F1.2 (50 IRE, AGC ON, Turbo mode) 3.0 lx at F1.2 (100 IRE, AGC ON, Turbo mode)	0.35 lx at F1.2 (30 IRE, AGC ON, Turbo mode) 0.7 lx at F1.2 (50 IRE, AGC ON, Turbo mode) 3.5 lx at F1.2 (100 IRE, AGC ON, Turbo mode)
AGC	ON/OFF switchable	
CCD IRIS	ON/OFF (switchable), 1/60 to 1/100,000 s	
White Balance (WB)	ATW	
Back-Light Compensation (BLC)	ON/OFF switchable	
S/N ratio	More than 50 dB (AGC OFF, Weight ON)	
Video out	BNC, 1.0 Vp-p, 75 Ω, sync. negative	
Operating temperature	-10°C to 50°C (14°F to 122°F)	
Storage temperature	-40°C to 60°C (-40°F to 140°F)	
Power requirements	AC 24 V ±10%, 60Hz or DC 12 V ±10%	
Power consumption	3.5 W	3.7 W
Auto iris lens	DC/video servo switchable	
Mass	360 g (13 oz)	
Dimensions (W x H x D)	60 x 54 x 120 mm (2 3/8 x 2 1/4 x 4 3/4 inches)	
Supplied accessories	Lens mount cap (1) Operating instruction (1)	

Rear View

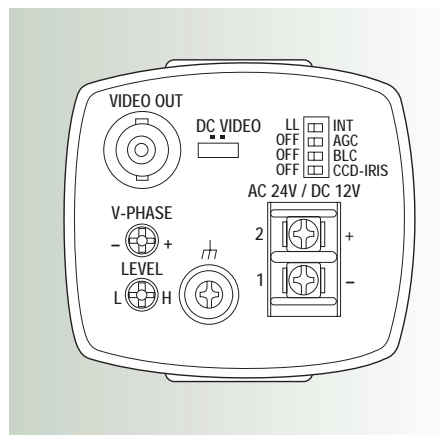

Dimensions

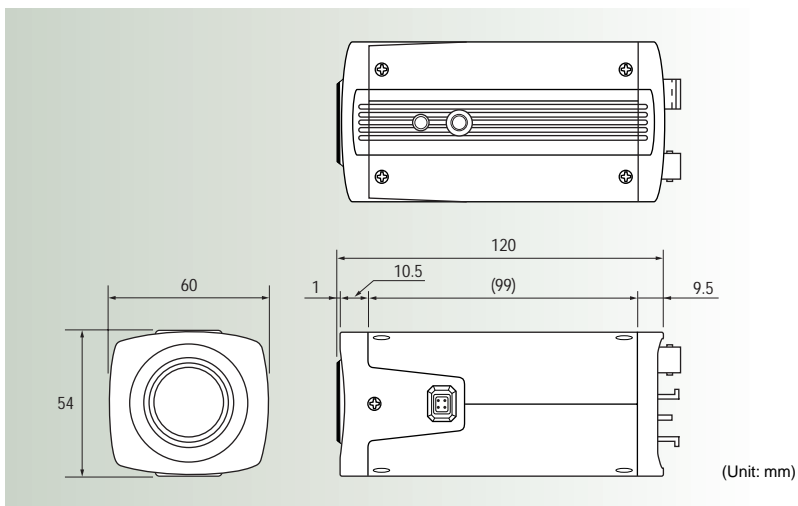

Distributed by

© 2002 Sony Corporation. All rights reserved.
 Reproduction in whole or in part without written permission is prohibited.
 Features and specifications are subject to change without notice.
 All non-metric weights and measures are approximate.
 Sony, Exwave HAD, Super HAD CCD and CCD IRIS are trademarks of Sony Corporation.