

Making security easier for you



SINGLE DOOR CONTROLLER PANEL FOR COMMERCIAL AND INDUSTRIAL APPLICATIONS

Supports Multiple Identification Technologies

- Magnetic stripe cards with Guardall's proprietary format
- Custom magnetic stripe cards using *Programmable Card Format*
- Wiegand cards & tokens with standard 26 bit encoding
- Wiegand cards & tokens with Guardall's proprietary format
- Proximity card readers with standard 26 bit Wiegand output

many Ways to Enter

- Identification by:
 - Authorized card *or*
 - Authorized card + PIN (personal identification number)
- Access with:
 - Single card
 - Single card with supervisor card lockout privilege
 - Dual card *or*
 - Escorted dual card
- Timed anti-passback
- Unlock by host immediately or after next valid card swipe

Large Capacity & Expandable

- Up to 2,000 card holders
- Standalone version with integrated programming keypad
- Plain version for use with access control host system

Secure

- Supports specific site/system code
- Tamper relay alerts alarm system of attempts to open controller
- Auxiliary output relay for alarm shunt or alarm signal

Optional Networked Features

- Daily access schedules for 14 groups of people
- Transmits events and access alarms for central logging or action
- Time schedules unaffected by communications interruptions
- Stores up to 1,000 time stamped events



Versatile Access Control

INOVA PDC single door controllers offer capacity and flexibility to control exactly who goes where and when within offices, warehouses, laboratories and other commercial/industrial facilities. These easy-touse panels adapt to access management needs with various modes of entry and a large cardholder capacity. Additional entry modes and access to daily time schedules are provided with the assistance of an on-line host.

Convenient Access

Authorized users can gain access by presenting their access card at a reader. The card is immediately checked and the door unlocked if the card is authorized for that entrance. Optionally, cardholders can be asked to enter a personal identification number (PIN) with their card to provide additional verification of identity prior to gaining entrance.

Where an auxiliary reader is being used as a request-to-exit reader, *card + PIN* can be required for entrance and *card only* for exiting.

Flexibility to Satisfy Your Needs

INOVA PDC door controllers deliver the flexibility to satisfy a wide range of access control needs. Single card access is the most common form of control. Another single card mode allows designated supervisors to lockout & rescind lockout of all nonsupervisor cards. Lockout of cards can also be initiated by a host system, regardless of whether supervisor privileges are available.

Where safety or security dictates that at least two people be present in an area, entrance can be granted in pairs only or, alternatively, in pairs with one person being an authorized escort.

If passing along of cards creates problems, the controller can disallow re-use of a card for up to 60 minutes after granting it access (timed antipassback).

Controlling Who Goes Where and When

When INOVA PDC door controllers are networked to a host server, they can limit when people are permitted to enter. 8 daily schedules are provided (7 days of the week + 1 holiday) for 14 groups of people. The unit will continue to control access by time if communications are disrupted. Events such as entrances, exits and alarms, can be date stamped and transmitted to the host for printing. If the unit goes off-line, the last 1,000 events are stored for later transmission.

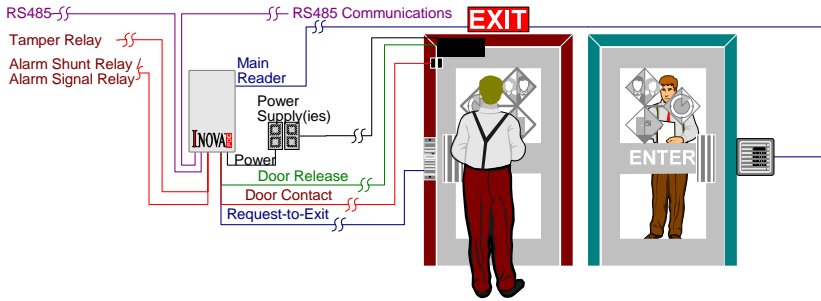

INOVA PDC Single Door Controller Specifications:

Functionality

User Identification: Magnetic stripe, proximity or Wiegand access cards
Site-specific code supported

Access Control Points: Entrances equipped with magnetic stripe or Wiegand swipe readers, including proximity readers. Standard 26 bit & VEREX proprietary Wiegand formats supported

Card Modes: Card entry or Card + PIN entry or
Card + PIN entry & Card only exit

Access Modes: Single card, Single card with supervisor lockout privileges †, Dual card or Escorted dual card †

Door unlocking: Unlock momentarily, Unlock maintained immediately or
Unlock maintained after the next valid card †

Card lockout: Card access active, Card access suspended, or
Card access suspended excepting supervisors †
Timed Anti-Passback: 1 to 60 minutes

Door Unlock Time: Programmable from 0 to 255 seconds.

Capacity

Max. Number of Cards: 2,000

Readers: 1 or 2 card readers for a single entrance
1 reader may have keypad for PIN entry or programming with the standard version

Access Schedules: 14 time zones (13 programmable + 1 pre-set) each with
8 daily schedules (7 weekdays + 1 holiday) †

Transaction Buffer: 1,000 time stamped events †
Inputs: Door status (open/closed/trouble) + Request-to-exit
Outputs: Door release + Alarm signal/Alarm shunt + Tamper

Reliability

Memory: Non-volatile - unaffected by power interruptions.

Scheduling: Access schedules during communications interruptions
† Feature available only when networked to a host

Physical Specifications

Power Supply / Charger: 12V DC \pm 2 V, \geq 150 mA + current draw for reader(s)
Environment: 0° - 55°C (32° - 122°F)

5-95% relative humidity, non-condensing

Dimensions (HxWxD): 22.9 x 13.3 x 5.0 cm (9.0 x 5.25 x 1.95 in.)

Cabling

Main Reader: w/keypad reader: 22 AWG, shielded, 13-17 conductors
w/no keypad reader: 22 AWG, shielded, 6-10 conductors

Auxiliary Reader: No keypad : 22 AWG, shielded 6 conductors

Cable Length to Readers: Magnetic stripe: 180m (600 ft)
Wiegand/Proximity: 150m (500 ft)

RS485 Communications: 24 AWG shielded, one pair, 120Ω
Belden 9841 or equivalent recommended
Maximum 1.2 km (~4,000 feet)

Power/Ground: 16 AWG, unshielded 2 conductors

Door Contacts : 22 AWG, unshielded 2 conductors

Output Relays: 22 AWG, unshielded 2 conductors

Installer Friendly

The door controller panel mounts away from the entrance in a secure location. Push-on connectors simplify wiring connections and service.

Local or Host Programming

Programming can be done:

- ▼ At a keypad card reader (standard version);
- ▼ On the integrated programming keypad (keypad version);
- ▼ From a host system.

With keypad programming, master cards set the controller to 'learn mode' to make card authorizations easy. In this mode all cards swiped through the reader are 'learned' and stored in memory. (Master programming cards are not required when programming is done entirely from a host system.)

Included with the controller:

- ▼ Standard version: Door controller with tamper and alarm signal/alarm shunt relays.
- ▼ Keypad version: Door controller with integrated programming keypad, tamper and alarm signal/alarm shunt relays.
- ▼ 2 magnetic stripe master programming cards + 2 labels for user supplied master cards.
- ▼ Installation & operating instructions.
- ▼ Mounting hardware and connectors

Options:

- ▼ Primary & auxiliary card readers. [P]
- ▼ 2 compatible Wiegand or proximity cards for use as Master Programming Cards if local programming is desired
- ▼ Packages of encoded access cards [P]
- ▼ *Using Custom Mag Stripe Cards* manual [P]

[P] Available from VEREX

© INOVA is a registered trademark of Guardall North America Inc.

All products are warranted against defects in workmanship or materials (details available upon request).

Installation guidelines are included in the instructions provided with each unit. Installers are responsible for knowing and complying with any local regulatory fire and building codes. In the interests of improving quality and design, the

VEREX Technology, a division of CSG Security, is constantly working to improve products and reserves the right to alter equipment designs and specifications without notice or obligation.

© 2002 CSG Security Inc. / Sécurité CSG Inc.

5201 Explorer Drive, Mississauga,
Ontario, L4W 4H1 Canada

Toll-free (USA & Canada): 1 877.249.9993
Phone: +1 905.206.8434
Fax: +1 905.629.4970

www.verextech.com sales@verextech.com

Rev. July, 2002